

## Media Wall

Continuing Mode-AL's commitment to developing products for industry specific applications, we are proud to introduce the all new Media Wall.

Consulting with our distributors, clients and industry specific experts, we have started with a blank canvas and using some of the ideas behind our internationally successful Monitor Stack system, we have produced the Media Wall range.

The Media Wall range is specifically targeted at the Security, Process and Retail industries as they tend to require off the shelf deliveries, fast on-site set up and a more cost effective product.

### MW What is the difference between a Monitor Stack and a Media Wall?

A Monitor Stack is individually tailored to each client's requirements with no limits on height, width or shape. Each screen is positioned so the faces are within 1mm of the adjacent screen faces and we routinely incorporate the following and a whole host of other requirements within the stack which is all contained within a depth of 180mm and has full cable management:

- UMD's (Under Monitor Displays)
- Clocks
- Speakers
- 19" rack mounted equipment
- Sequential start power distribution
- Optical repeaters
- MEU's (Multiformat Engine Units)



Unit 4 Anamax Industrial Park, Oxford Road  
Tatting End, Bucks, SL9 7BB

## Media Wall

The Media Wall has been designed with a very different purpose:

### The most economical way of mounting multiple screens both space and cost wise



The most important feature we have taken from our Monitor Stack range is the cable management, as this was the key to our development focus group's requirements. Secondly, our unique screen mounting brackets allow the removal of the screen with as little as 5mm clearance between the screens above and adjacent to it and of course our bank tilt, which allows a whole bank of screens to be tilted to the same angle, significantly reducing the set-up time.

A Media Wall has 3 leg heights - 2.0m, 2.2m and 2.4m

The legs have optional 4" cable trays; allowing the client to specify how many vertical trays are required. We have optional end covers for the legs, but to keep the cost down, these will only be needed if the legs are in view. And finally, the Media Wall has optional bolt down bases instead of feet.

The Media Wall has customer definable beam lengths up to 3.2m between legs and a choice of sizes of beam - 60, 120 and 180mm deep. Each beam has a 3" cable tray as standard, with options of 2" and 4" available if required. Optional under slung cable tray brackets bring Monitor Stack versatility to the Media Wall range. We also have a new development of stub beams, allowing screens to be mounted on short sections of beam cantilevered out from the legs.



Tel: 01753 880824, Fax: 0870 1359413  
E: sales@mode-al.co.uk, W: www.mode-al.co.uk

## Media Walls

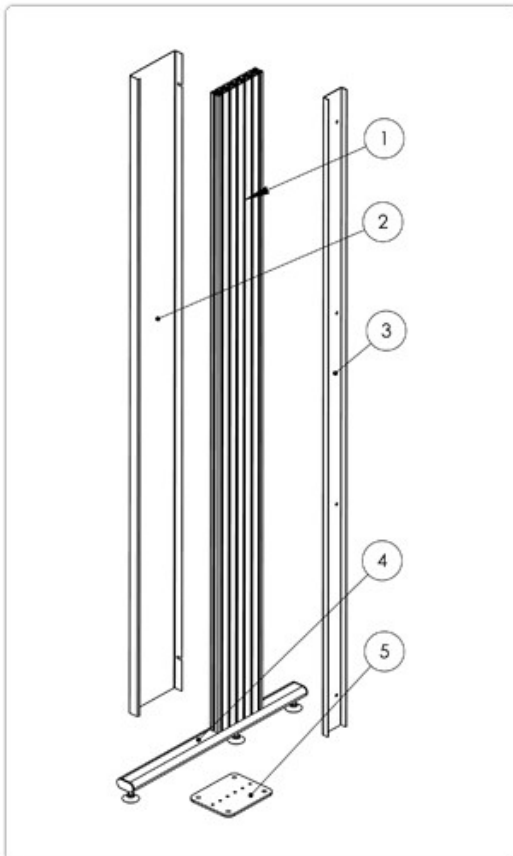

## Media Walls

### Media Wall Legs

- 1.) Extruded upright 180 x 30mm with length choice of 2.0, 2.2 or 2.4m
- 2.) End cover manufactured from pre-anodised aluminium finish. Powder coat option is available as a special order to any RAL or BS paint finish.
- 3.) Cable Tray 100mm (4") as standard. Includes stand offs to allow for easy cable installation. Options of 75mm (3") and 50mm (2") trays also available.
- 4.) Standard foot with levelling feet allows for  $\pm 10$ mm of height adjustment. Powder coated Mode-AL silver as standard. Can be colour matched to the end covers as a special order.
- 5.) Bolt down base - ideal for reducing the foot print of the stand or for high traffic areas



Unit 4 Anamax Industrial Park, Oxford Road  
Tatting End, Bucks, SL9 7BB



Tel: 01753 880824, Fax: 0870 1359413  
E: sales@mode-al.co.uk, W: www.mode-al.co.uk

## Media Walls

## Media Walls



Standard Foot		
Part No:	Height (M)	Price
MW-LS-01	2.0 (2.066)	<b>£305.90</b>
MW-LS-02	2.2 (2.266)	<b>£319.60</b>
MW-LS-03	2.4 (2.466)	<b>£333.20</b>
Bolt Down Base		
Part No:	Height (M)	Price
MW-LB-01	2.0 (2.006)	<b>£279.10</b>
MW-LB-02	2.2 (2.206)	<b>£292.75</b>
MW-LB-03	2.4 (2.406)	<b>£306.40</b>

Cable Tray			
Height (M)			
Part No:	2.0	2.2	2.4
CT-100	<b>£82.30</b>	<b>£82.30</b>	<b>£82.30</b>
CT-075	<b>£76.20</b>	<b>£76.20</b>	<b>£76.20</b>
CT-050	<b>£72.35</b>	<b>£72.35</b>	<b>£72.35</b>
End Covers			
Height (M)			
Part No:	2.0	2.2	2.4
EC-01	<b>£60.20</b>	<b>£64.35</b>	<b>£71.10</b>



Unit 4 Anamax Industrial Park, Oxford Road  
Tatting End, Bucks, SL9 7BB



Tel: 01753 880824, Fax: 0870 1359413  
E: sales@mode-al.co.uk, W: www.mode-al.co.uk

## Media Walls

## Media Walls

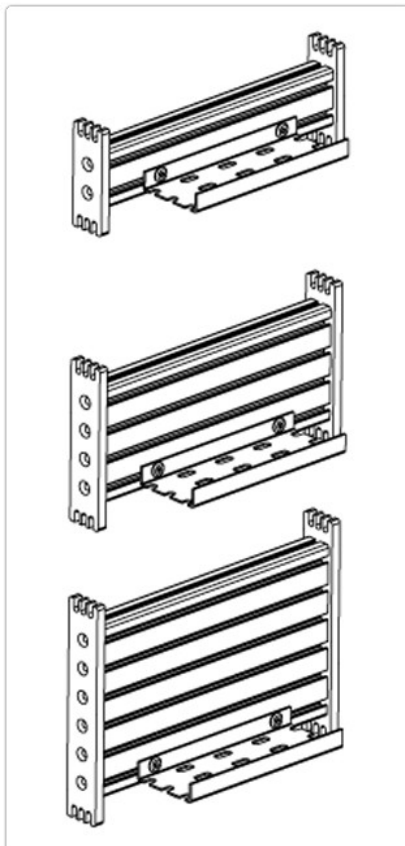

### Beams

Beams come in 3 sizes - 60, 120 and 180mm deep and a 75mm (3") cable tray as standard with optional 50mm (2") and 100mm (4") trays available. Maximum beam lengths are:

B-06-3-xxxx 60 x 30mm beam max length 2.2m

B-12-3-xxxx 120 x 30mm beam max length 2.8m

B-18-3-xxxx 180 x 30mm beam max length 3.2m

Typical part number **B-12-3-1870** (beam 120mm deep with 75mm (3"))

Part No:	Cost per mm	Standing	Total
B-06-3-xxxx	<b>£0.020</b>	<b>£60.05</b>	
B-12-3-xxxx	<b>£0.036</b>	<b>£60.05</b>	
B-18-3-xxxx	<b>£0.057</b>	<b>£64.37</b>	
<b>Example 1</b>			
<b>B-12-3-1870</b>	1870 x 0.036 =	+ <b>£60.05</b>	= <b>£127.37</b>

For 50mm (2") cable tray, change Part No to B-xx-2-xxxx

For 100mm (4") cable tray, change Part No to B-xx-4-xxxx



Unit 4 Anamax Industrial Park, Oxford Road  
Tatting End, Bucks, SL9 7BB



Tel: 01753 880824, Fax: 0870 1359413  
E: sales@mode-al.co.uk, W: www.mode-al.co.uk

## Media Walls

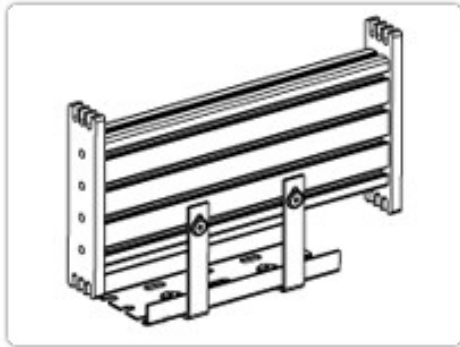
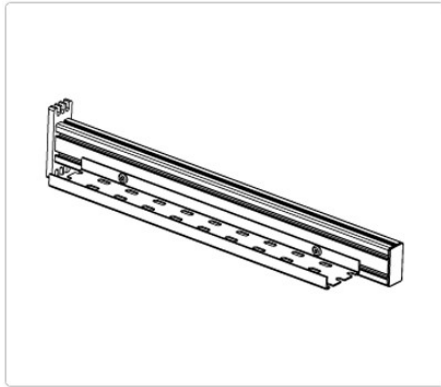

## Media Walls

### Stub Beams

These are very handy when you have a large screen and need to put smaller screens down the side of the large screen (example 1) Max length 600mm. Max load as follows:

S06-3-xxx max load 16kg - **£45.70** each

S12-3-xxx max load 21kg - **£57.30** each

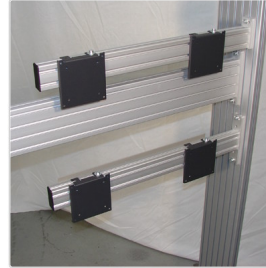

### Cable Tray Brackets

To under sling the cable tray, you will need cable tray brackets.

Trays up to 1.0m long - require 2 brackets

Trays 1.0 - 2.0m long - require 3 brackets

Trays 2.0 - 3.0m long - require 4 brackets

CT-02 - **£4.00** each + VAT

(includes all fixings)



Unit 4 Anamax Industrial Park, Oxford Road  
Tatling End, Bucks, SL9 7BB



Tel: 01753 880824, Fax: 0870 1359413  
E: sales@mode-al.co.uk, W: www.mode-al.co.uk

## Media Walls

### Screen Mounts

The 3 types of screen mounts below will mount 97% of all screens in production today including Clarity, Vutrix and Barco screens. There are a few noted exceptions such as the Sharp LC65GD1E, the NEC 61XM2 and the Panasonic 103" screen. To mount these screens, we will happily supply the mounts from our Monitor Stack range at a comparable price to our Beam Universal mount if necessary.

The mounts come with all the necessary fixings and full instructions

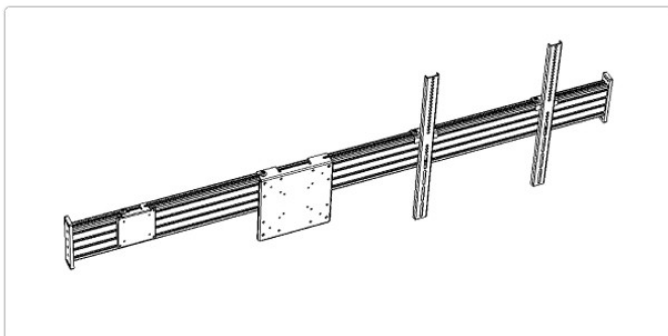

## Media Walls

Part No:	MA-V-13	MA-V-15	MA-U-23
Description	Beam VESA 100	Beam VESA 200	Beam Universal
Size	75 x 75mm	75 x 75, 100 x 100mm	Any width x 450 high
	100 x 100mm	100 x 200, 200 x 200mm	
		Clarity	
Lift for removal	5mm	5mm	20mm
Fixing	Single screw	Single screw	Dual screw
Price	<b>£18.75</b>	<b>£36.50</b>	<b>£55.90</b>



Unit 4 Anamax Industrial Park, Oxford Road  
Tatling End, Bucks, SL9 7BB



Tel: 01753 880824, Fax: 0870 1359413  
E: sales@mode-al.co.uk, W: www.mode-al.co.uk