

MAX LOAD RATING = 75kg
 SCREEN TO SCREEN ARM FIXINGS = MIN M6
 WALL TO WALL BRACKET FIXINGS = MIN M8

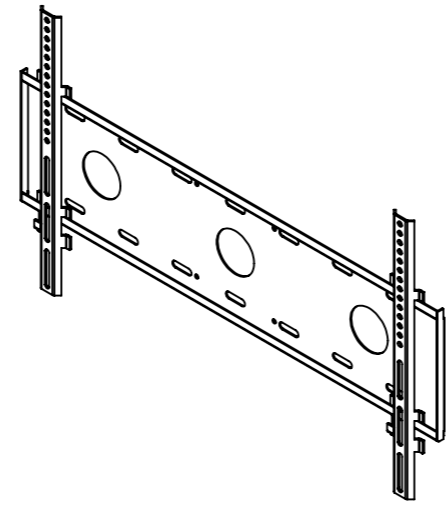

DEBUR AND BREAK SHARP EDGES		Mode-AL.com	
MATERIAL: MILD STEEL		UNIT 4 ANAMAX IND. PARK. OXFORD ROAD, TATLING END, BUCKS SL9 7BB TEL +44 (0)1753 880824	
FINISH: PPC BLACK		TITLE: SLIM JIM WALL MOUNT	
UNLESS OTHERWISE SPECIFIED: DIMENSIONS ARE IN MILLIMETRES TOLERANCES: LINEAR: X. ±1.0mm X.X ±0.25 mm X.XX ±0.10 mm ANGULAR: X.XX ±0.1°		DWG NO. MA-OEM-10	REV B
SCALE: 1:1	SHEET 1 OF 1	A3	