

SWISS PAIR
(AS PER SAMPLE)

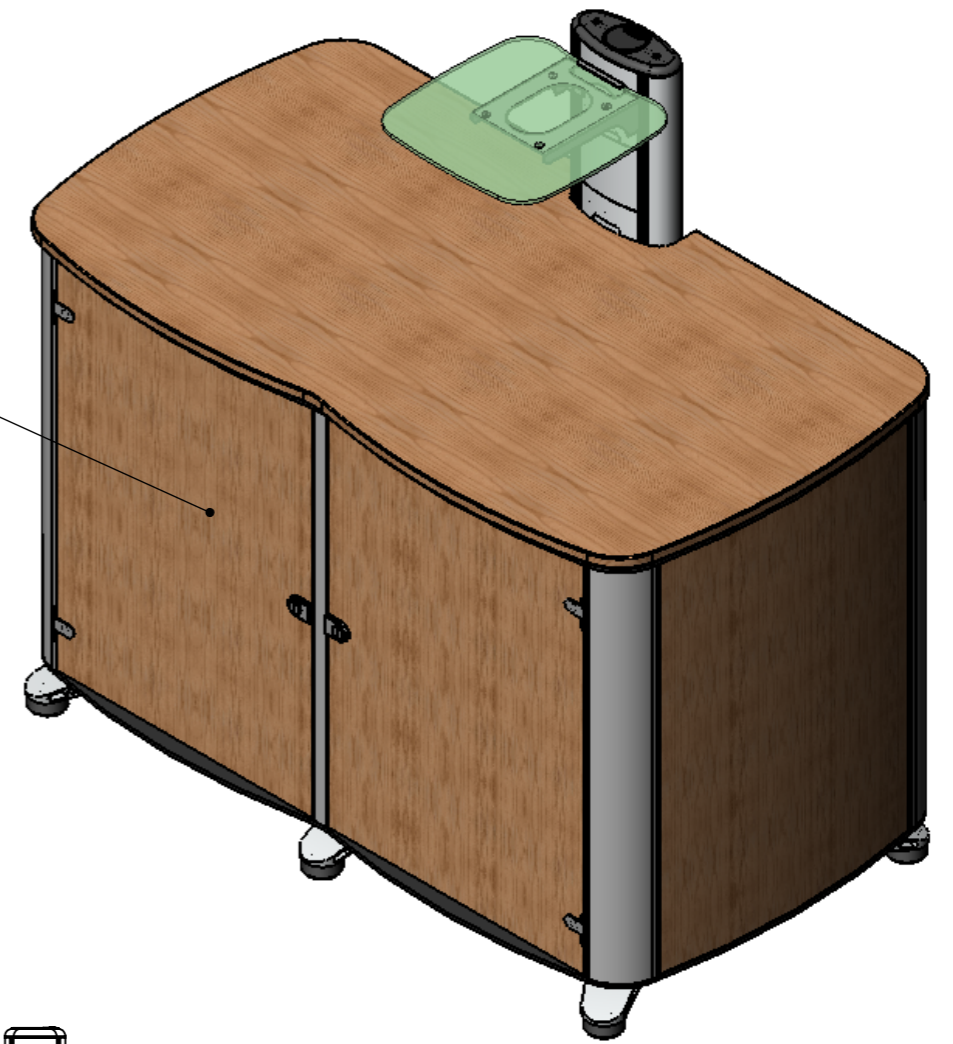

ES-03 300x300
SHELF (GLASS)
HEIGHT ADJUSTABLE

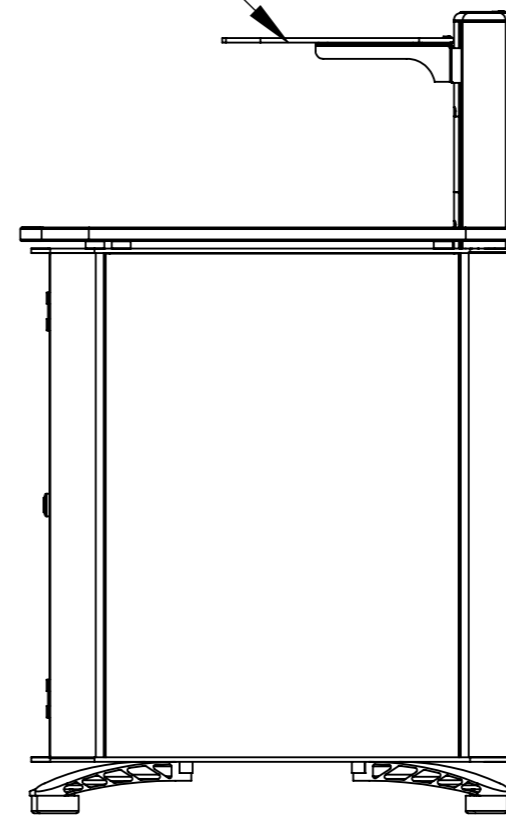
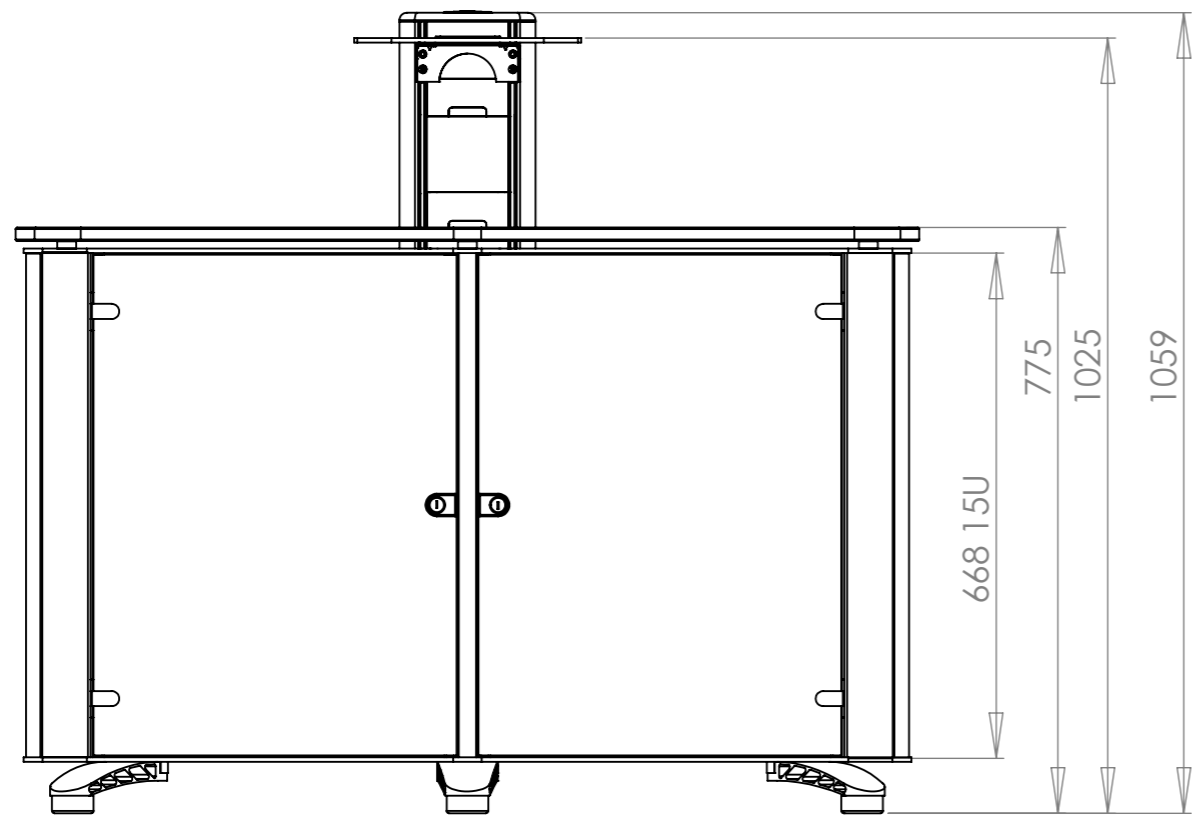

REMOVABLE
COVER

REAR ACCESS

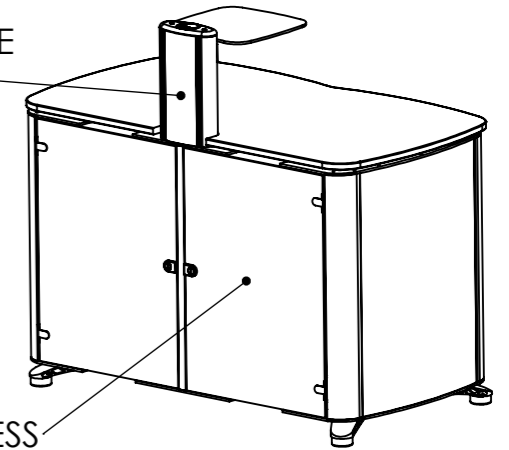

DEBUR AND BREAK SHARP EDGES		Mode-AL.com UNIT 4 ANAMAX IND. PARK. OXFORD ROAD, TATLING END, BUCKS SL9 7BB TEL +44 (0)1753 880824
MATERIAL: SEE DWG		
FINISH: SWISS PAIR		TITLE: EC1515DV WITH CAMERA SHELF
UNLESS OTHERWISE SPECIFIED: DIMENSIONS ARE IN MILLIMETRES TOLERANCES: LINEAR: X. ±1.0mm X.X ±0.25 mm X.XX ±0.10 mm ANGULAR: X.XX ±0.1°		DWG NO. MA-F21-424-01
		REV A
SCALE: 1:10		SHEET 1 OF 1 A3